



Date: April 28, 2021  
To: Weber County Board of County Commissioners  
From: Sean Wilkinson, AICP *SW*  
Director, Community Development Department  
Subject: **Request for approval of the First Addendum to the Wireless Communications Tower Lease with Liberty Broadband**  
Agenda Date: May 4, 2021  
Documents: Exhibit A: Wireless Communications Tower Lease – First Addendum  
Exhibit B: Equipment Location on Tower  
Exhibit C: Equipment Specifications

---

**Summary:**

Weber County approved a tower lease agreement with Liberty Broadband in November 2019. Liberty Broadband has recently requested approval of an addendum to the lease agreement to upgrade and replace its equipment on the tower. The existing equipment will be replaced with two CommScope SF-U12-3-126 sector frames. This equipment will be located on the tower as shown in Exhibit B. The new equipment will not cause interference problems for the Ogden Valley Recreation/Transmission Special Service District or Verizon Wireless, which are existing lessees.

The addendum contains a non-interference provision which states that the County will not allow any company except for the Ogden Valley Recreation/Transmission Special Service District and Verizon Wireless to lease, sublease, or operate, the following unlicensed RF Frequencies: 5.260-6.3GHz, 24.05-24.25GHz, 57-71GHz.

The lease term begins on May 4, 2021 and terminates on May 4, 2025. Lease payments will increase from \$400 to \$600 per month.

**WIRELESS COMMUNICATIONS TOWER LEASE  
(FIRST ADDENDUM)**

The Wireless Communications Tower Lease dated November 5, 2019 by and between Weber County ("Landlord") & Liberty Broadband LLC ("Tenant") is hereby modified as follows:

**PREMISES.** Landlord, in consideration of the lease payments provided in this Lease, leases to Tenant sufficient area on the main tower to mount two CommScope SF-U12-3-126 sector frames, located at 4964 N. Powder Mountain Rd, Eden, UT 84310 (the "Premises").

**NON-INTERFERENCE.** Landlord will not allow any other company (except for the Ogden Valley Recreation/Transmission Special Service District and Verizon Wireless) to lease, sublease, nor operate on the Premises, the following unlicensed RF Frequencies: 5.260-6.3GHz, 24.05-24.25GHz, 57-71GHz.

**TERM.** The lease term will begin on May 4, 2021 and will terminate on May 4, 2025.

**LEASE PAYMENTS.** Tenant shall pay to Landlord monthly installments of \$600.00, payable in advance on the seventh day of each month. Lease payments shall be made to the Landlord at 2380 Washington Blvd, Ogden, Utah 84401. The payment address may be changed from time to time by the Landlord.

IN WITNESS WHEREOF, the undersigned have affixed their respective signatures hereto.

BOARD OF COUNTY COMMISSIONERS  
OF WEBER COUNTY

By:

Attest:

\_\_\_\_\_  
James H. "Jim" Harvey, Chair

\_\_\_\_\_  
Ricky Hatch, CPA  
Weber County Clerk/Auditor

LIBERTY BROADBAND LLC

By:

Attest:

\_\_\_\_\_  
Michael Zindel, CEO

\_\_\_\_\_



## SF-U12-3-126

Universal Sector Frame, 12 ft face, includes pipe mounts

**OBSOLETE**

This product was discontinued on: July 31, 2015

**Replaced By:**

SF-SU12-3-126

Stand-Off Sector Frame, 12 ft face, includes pipe

## Product Classification

**Product Type** Tower sector frame

## General Specifications

**Mounting** Angle 60°, 203.2 mm (8 in) | Angle 90°, 152.4 mm (6 in) | Straight or tapered legs up to 203.2 mm (8 in) OD

**Note** Four 72 in x 8 in panel antennas per sector

**Pipe, quantity** 3

**Tower Taper** Non-tapered | Tapered

## Dimensions

**Height** 3,200.4 mm | 126 in

**Face Width** 3.81 m | 12.5 ft

**Width** 3810 mm | 150 in

**Length** 609.6 mm | 24 in

**Pipe Length** 3,200.4 mm | 126 in

**Mounting Diameter, maximum** 203.2 mm | 8 in

**Mounting Diameter, minimum** 0 mm | 0 in

**Pipe Outer Diameter** 60.96 mm | 2.4 in

**Stand-off Distance** 609.6 mm | 24 in



# SF-U12-3-126

## Outline Drawing

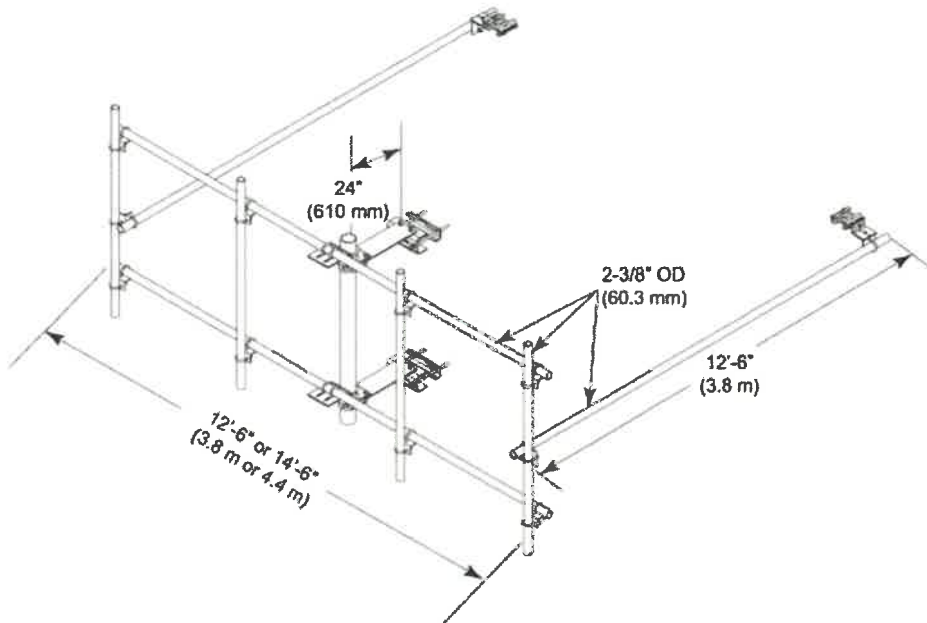

## Material Specifications

**Material Type** Hot dip galvanized steel

## Mechanical Specifications

**Wind Rating** 120 mph (BWS) at 150 ft AGL | 140 mph (3-second gust) at 150 ft AGL using Exposure D per FBC

**Wind Rating Test Method** TIA/EIA-222

## Environmental Specifications

**EPA with 1/2 in (12 mm) radial ice** 1.403 m<sup>2</sup> | 15.1 ft<sup>2</sup>

# SF-U12-3-126

---

<b>EPA without ice</b>	1.003 m <sup>2</sup>   10.8 ft <sup>2</sup>
<b>Man Rating</b>	250 lb vertical man load at 15 mph (BWS)

## Packaging and Weights

<b>Included</b>	Clamps   Frame   Pipe mounts   Saddle mounts   Stiff arm
<b>Packaging quantity</b>	1
<b>Weight, net</b>	243.08 kg   535.9 lb

## Regulatory Compliance/Certifications

<b>Agency</b>	<b>Classification</b>
ISO 9001:2015	Designed, manufactured and/or distributed under this quality management system



## Included Products

- MT-537 — Plain End Pipe, 2-3/8 in OD x 126 in
- SF-U12-B — Universal Sector Frame, 12 ft face

## \* Footnotes

<b>EPA with 1/2 in (12 mm) radial ice</b>	EPA—w Effective Projected Area
<b>EPA without ice</b>	EPA—w Effective Projected Area
<b>Man Rating</b>	BWS—w Base Wind Speed
<b>Wind Rating</b>	BWS—w Base Wind Speed; FBC—Florida Building Code